

JNILOCK®

J-CARA®
MODULAR SYSTEM
ASSEMBLY GUIDE

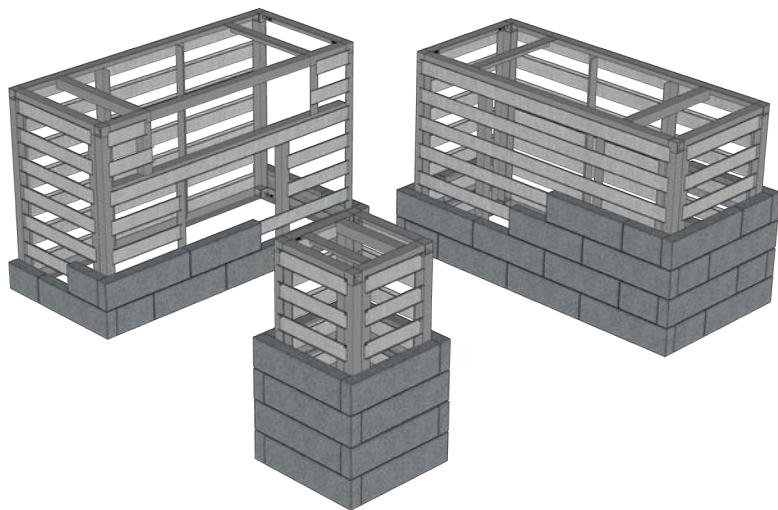

TABLE OF CONTENTS

TOOLS	3
BASE OPTIONS	4-7
BASE MODULE	8-13
GRILL MODULE	14-19
CORNER MODULE.....	20-21
PILLAR MODULE	22-25
BACK CORNER.....	26-27
END-CLAD KIT.....	28-29
BACKSPLASH.....	30-35
CONNECTING MODULES.....	36-37
MODULE DIMENSIONS.....	38-39
STANDALONE BAR/FIRE TABLE/GRILL.....	40-41
EXTENDING MODULES.....	42-43
L-SHAPE KITCHEN.....	44-45
U-SHAPE KITCHEN.....	46-47

TOOLS



SAFETY GLASSES



9/16" WRENCH



8" DRILL BIT EXTENDER



GLOVES

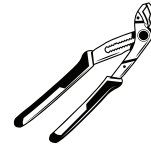

PLIERS

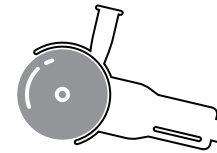

ANGLE GRINDER

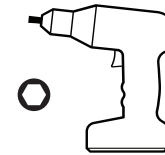

DRILL + 5/16" HEX BIT



HEARING PROTECTION

BASE OPTIONS

GRANULAR

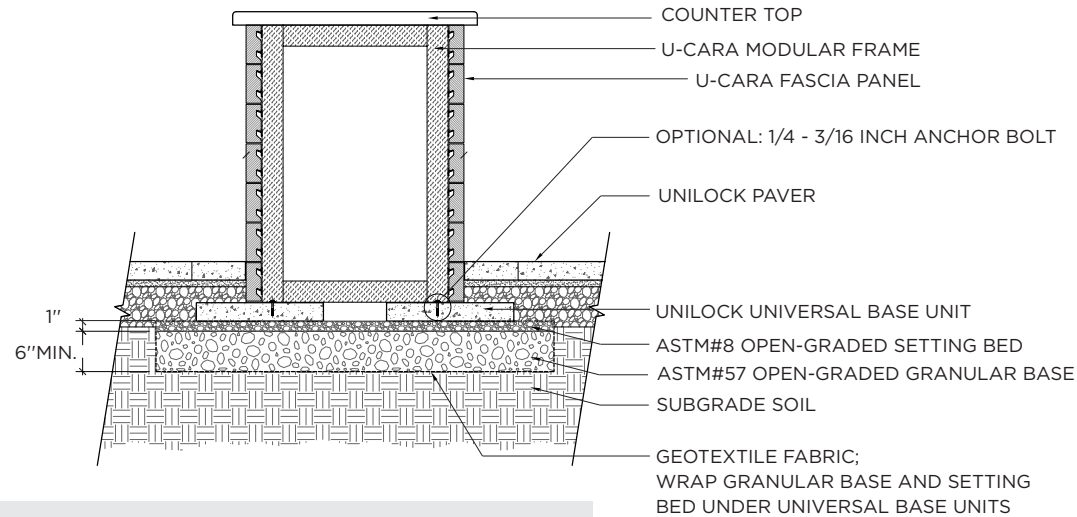

NOTE:

This base option is acceptable for standalone single units. A poured-in-place slab is recommended if connecting multiple units.

CONCRETE SLAB



NOTE:

When combining multiple units, a poured concrete slab on a footing is recommended.

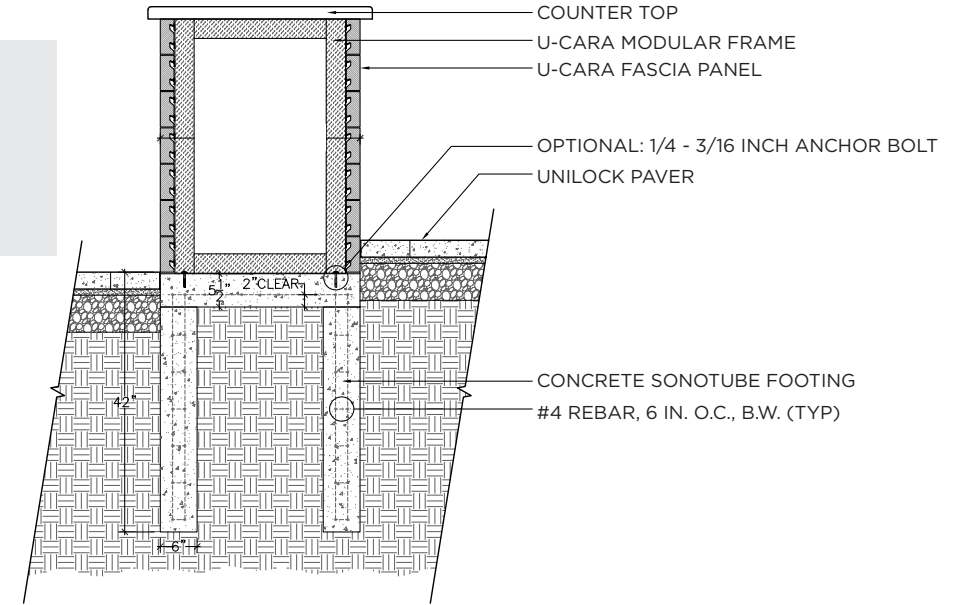

BASE OPTIONS

ROOFTOP PEDESTAL (TYPICAL)

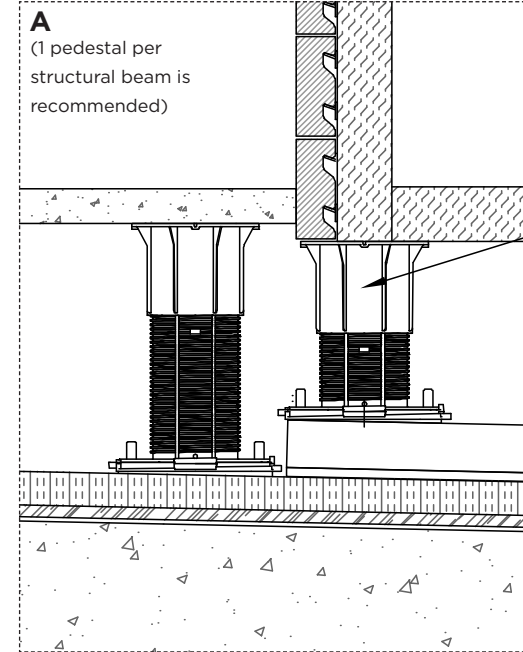
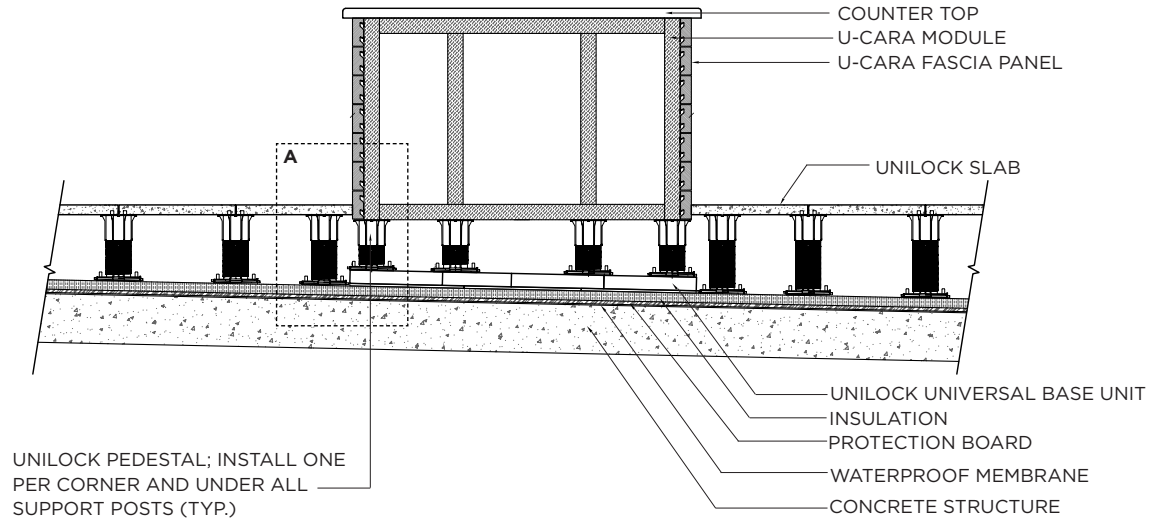

NOTE:

Always consult with project engineer/architect for site specific details.

Example for Standalone Modular Unit:

- Granite top with a total weight of 2,000 lbs
- 8 pedestals @ 250 lbs each or approx. 15.34 SQFT @ 130 lbs/SQFT (based on a 32" x 69" footprint)

BASE MODULE

SPECIFICATIONS

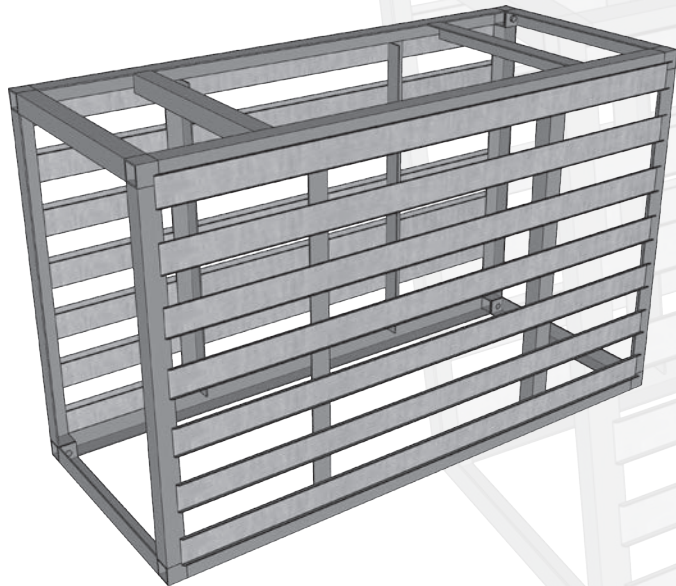

DIMENSIONS

32½" x 69½" (OUTSIDE TO OUTSIDE)

WEIGHT

WITHOUT END = 59 LBS

WITH END = 81 LBS



NOTE:

Base module has 2 open ends (no rail) to accommodate connections.

MODEL: UL-BC

WHAT'S INCLUDED

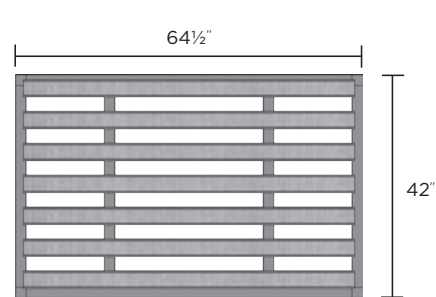

ULBCP BASE MODULE PANEL 2x



ULCS CONNECTING STRUT 4x



ULHAR HORIZONTAL ADJUSTABLE RAIL 2x

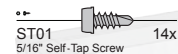

ST01 5/16" Self-Tap Screw 14x

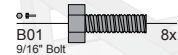

B01 9/16" Bolt 8x



LW01 3/8" Lock Washer 8x

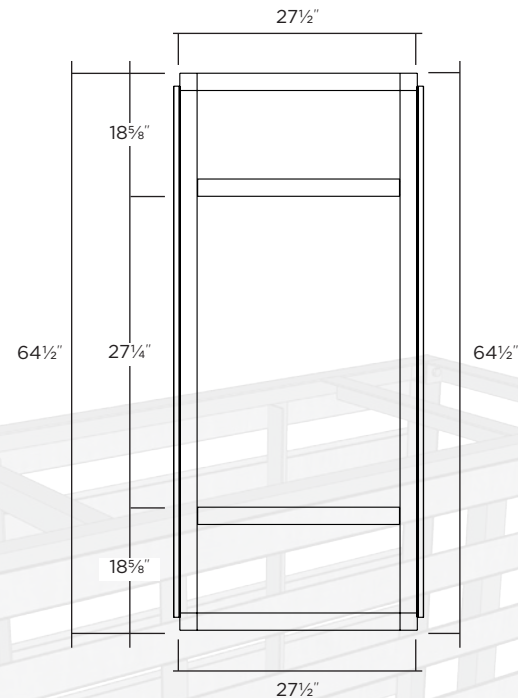

BASE MODULE

ASSEMBLY

MODEL: UL-BC

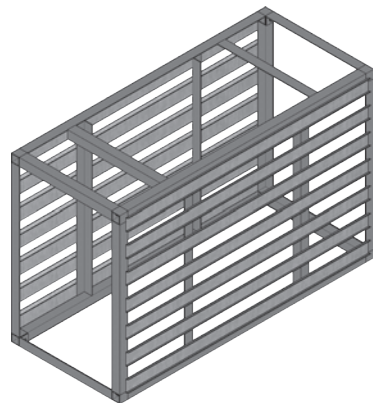
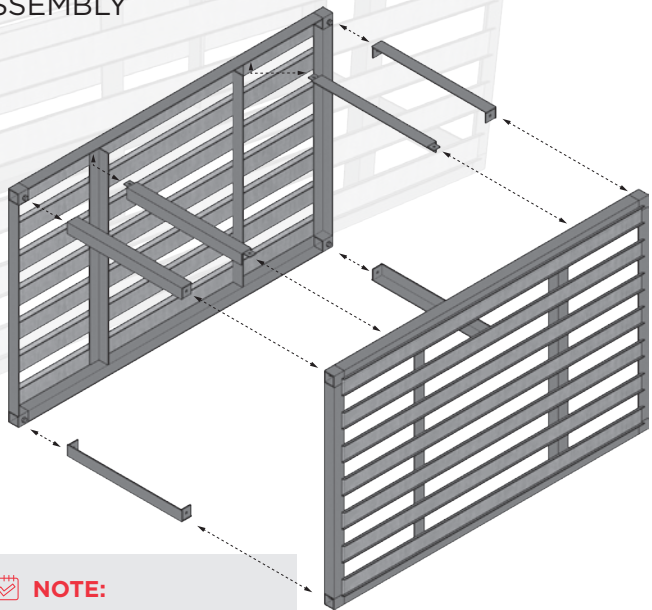

NOTE:

If oversized stand-alone bar unit is desired, 2 End Clad Kits are required (UL-ECK-OS).

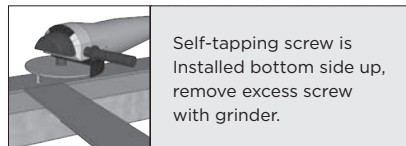

Self-tapping screw is installed bottom side up, remove excess screw with grinder.

BASE MODULE

STAND-ALONE UNIT (WITH END-CLADDING)

MODEL: UL-BC

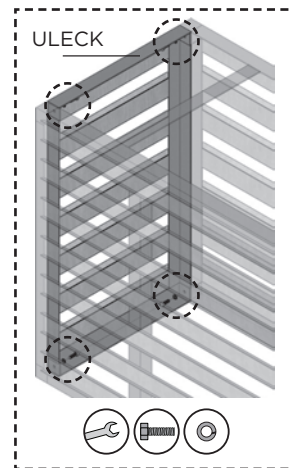

NOTE:

For stand-alone unit 2 end-clad kits (UL-ECK) are required.



NOTE:

Remove connecting struts and replace with end-clad panel using existing hardware.

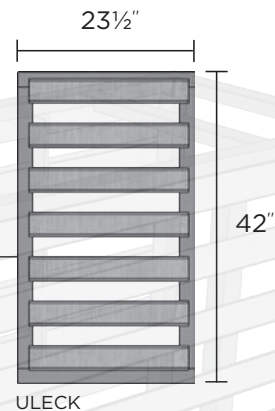
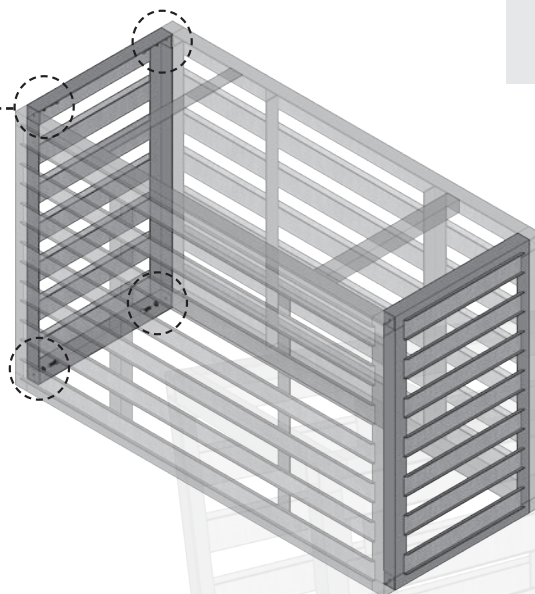

ULECK

BASE MODULE

MODEL: UL-BC

OUTDOOR FRIDGE CUT-OUT OPTION

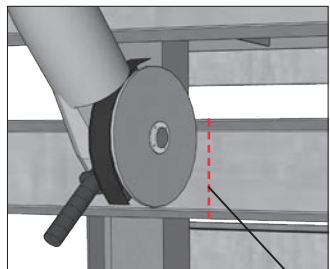

NOTE:

Cut opening to provide sufficient clearance for refrigerator. (24"-27" wide). Top and bottom support beams should not be cut.

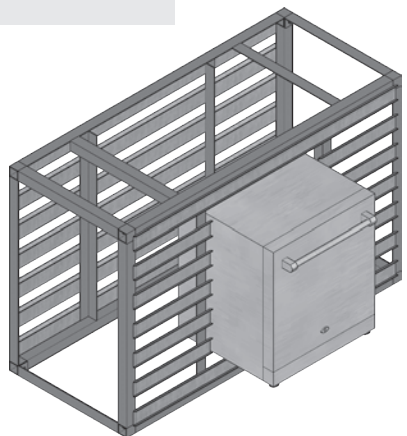
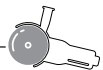
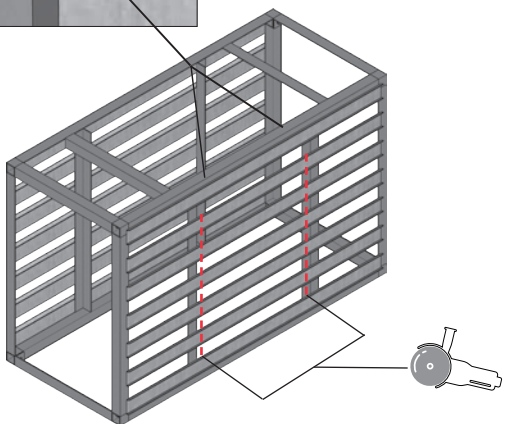

BASE MODULE

MODEL: UL-BC

FIRE TABLE OPTION



NOTE:

Use adjustable rail to provide support for fire pan.



CAUTION:

Refer to manufacturer requirements for clearances and ventilation needed for Natural Gas/Propane burner insert.

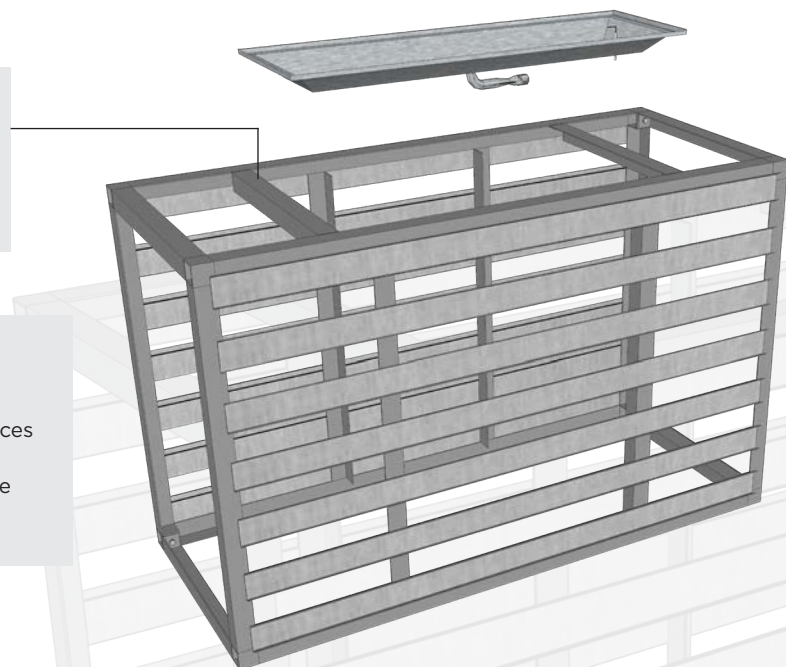

GRILL MODULE

SPECIFICATIONS

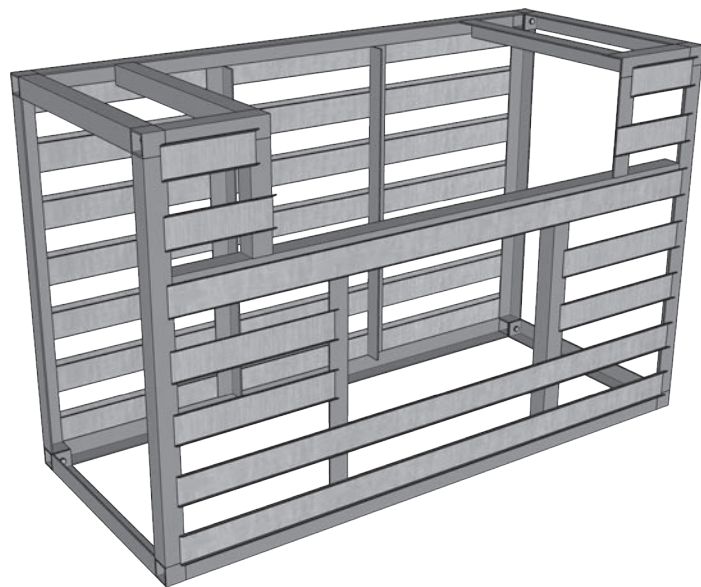

NOTE:

Note: Grill Module has 2 open ends (no rail) to accommodate connections.

WHAT'S INCLUDED

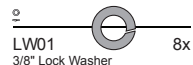
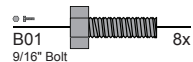
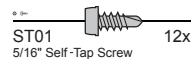

ULCS
Connecting Strut 4x



ULHAR
Horizontal Adjustable Rail 2x

MODEL: UL-GC



NOTE:

Rail is removed by unscrewing the self-tapping screws to accommodate various grill head dimensions.

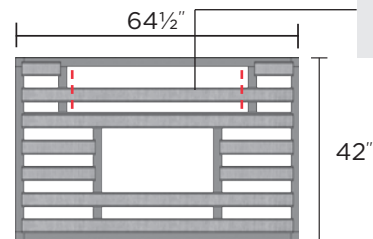

FRONT PANEL 1 PC.
GRILL MODULE (ULGCFP)

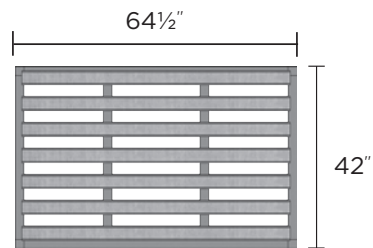

BACK PANEL 1 PC.
GRILL MODULE (ULGCFP)

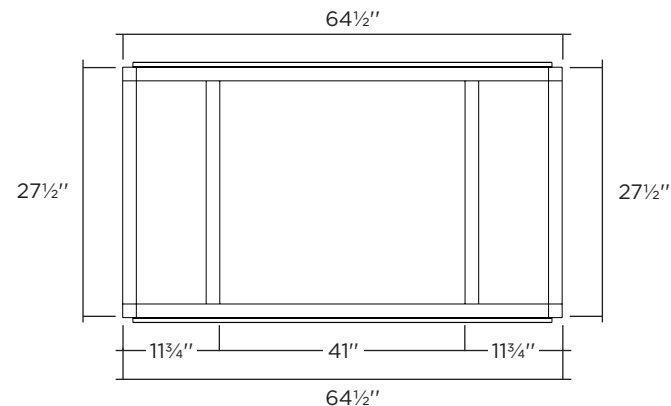

DIMENSIONS WITH FASCIA PANEL

32½" x 69½" (OUTSIDE TO OUTSIDE)

WEIGHT

WITHOUT END = 59 LBS

WITH END = 80 LBS

GRILL MODULE

ASSEMBLY - STANDARD WIDTH

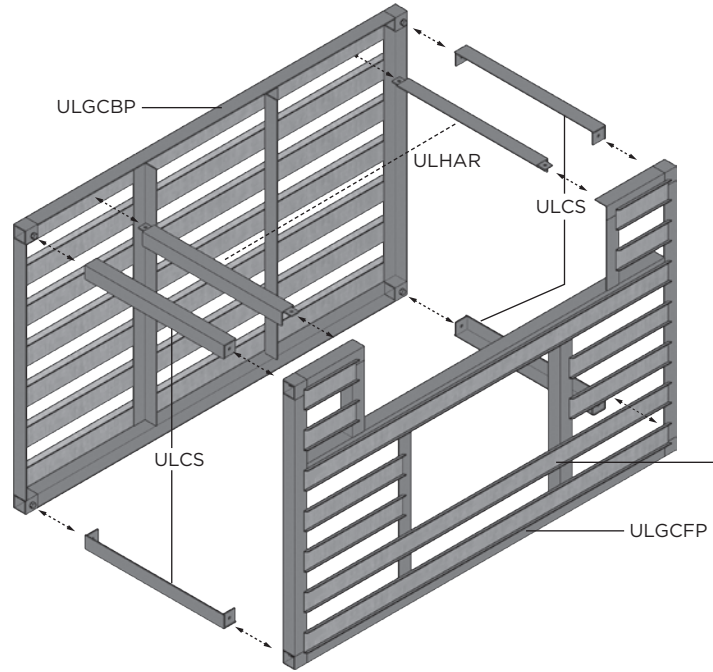

NOTE:

Rough door opening:

17 $\frac{3}{8}$ " H x 27 $\frac{1}{16}$ " W
U-Cara 27" stainless steel DBL door available to fit opening without metal modification.

MODEL: UL-GC

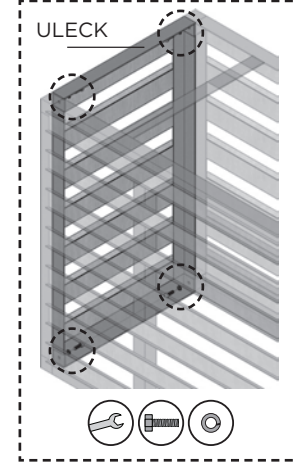

NOTE:

Grill Module has 2 open ends (no rail) to accommodate connections.

If stand-alone grill is desired, 2 End-Clad Kits are required.
Standard - UL-ECK
Oversized - UL-ECK-OS

23 $\frac{1}{2}$ " (STANDARD) UL-ECK
32 $\frac{1}{4}$ " (OVERSIZED) UL-ECK-OS



UL-ECK 2X

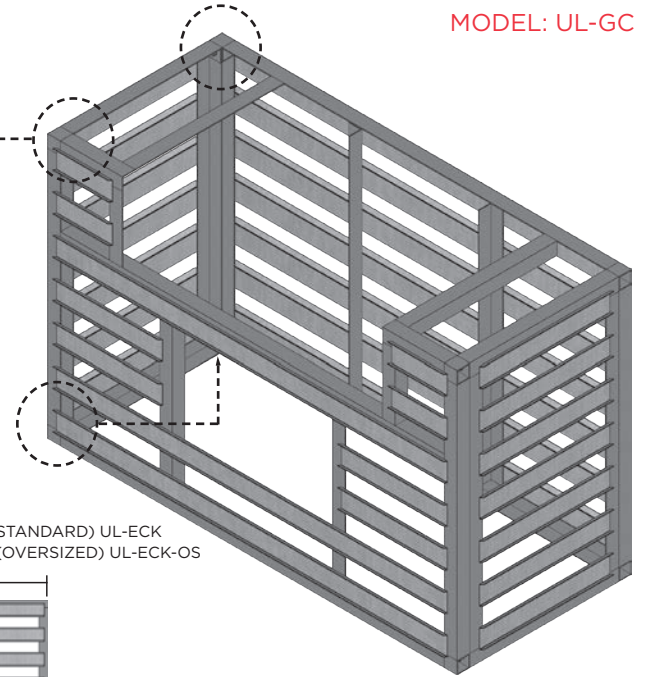

GRILL MODULE

GRILL CUT-OUT

Typical for 42" drop down grill.
Decrease cut-out dimension for
smaller grills.

Grill module can accommodate
up to a 42" grill.

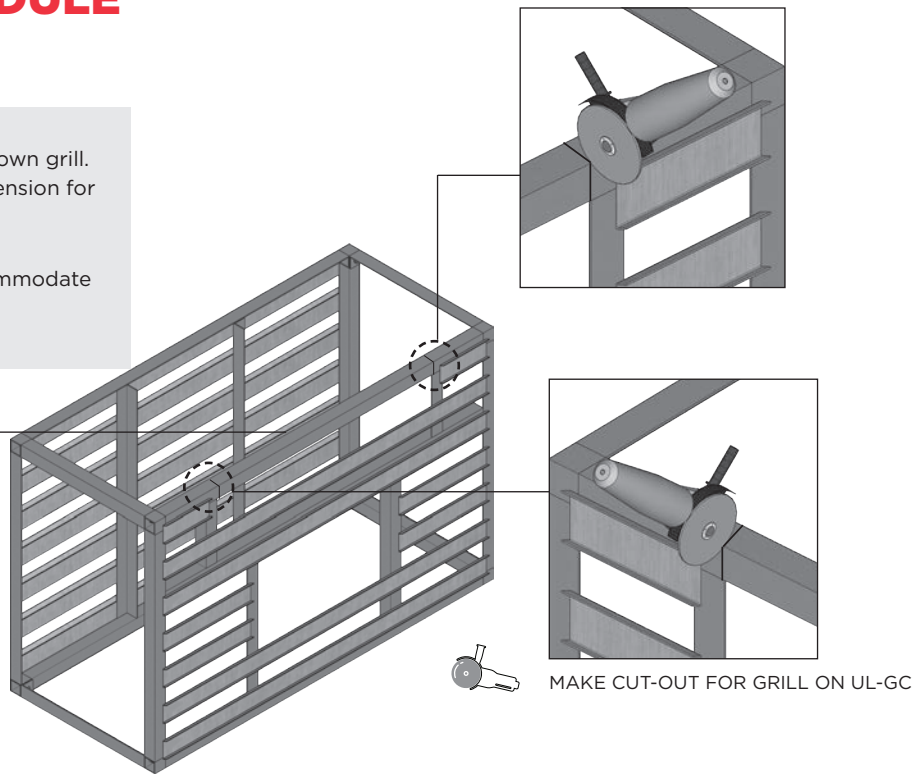

MODEL: UL-GC

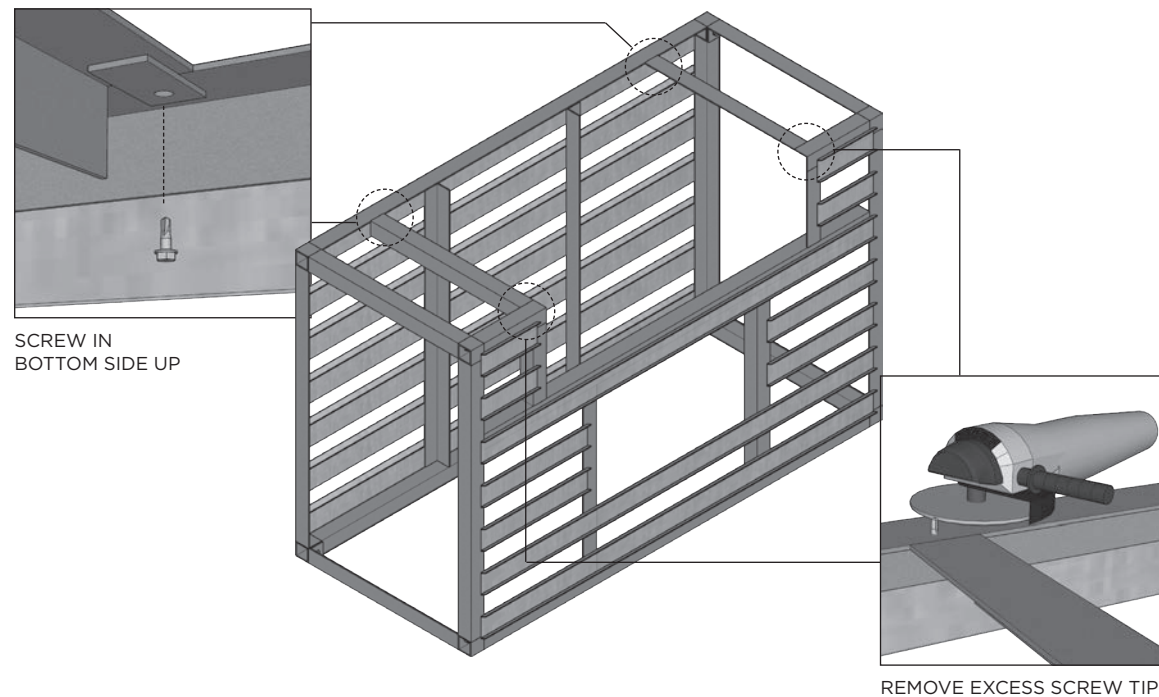

CORNER MODULE

STANDARD WIDTH

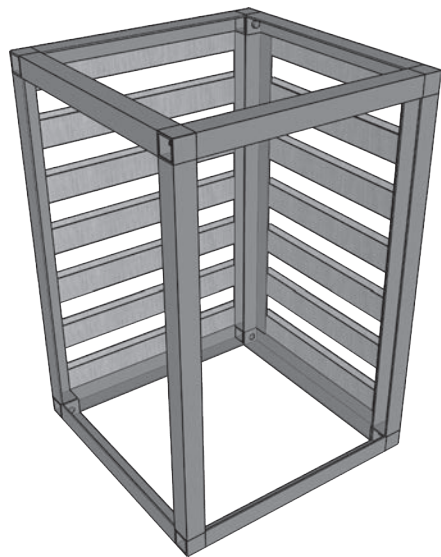

WHAT'S INCLUDED

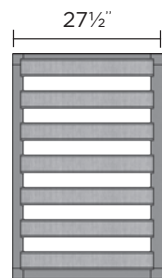

ULCCBP 1X
CORNER MODULE
BACK PANEL

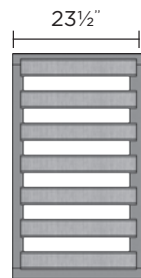

ULECP 1X
END-CLAD PANEL

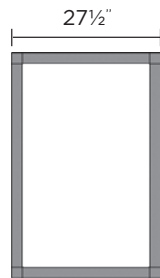

ULCCFP 1X
CORNER MODULE
FRONT PANEL

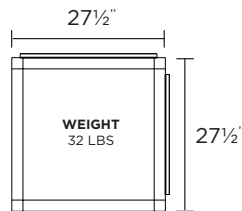
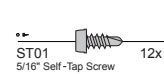
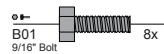

OVERSIZED WIDTH

MODEL: UL-CC

WHAT'S INCLUDED

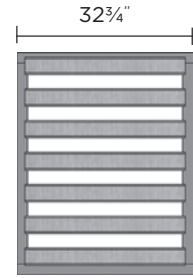

ULECP OS 1X
END-CLAD PANEL
OVERSIZED

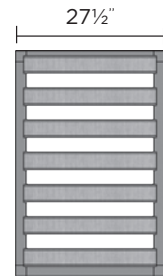

ULCCBP 1X
CORNER MODULE
BACK PANEL



ULCCFP 1X
CORNER MODULE
FRONT PANEL

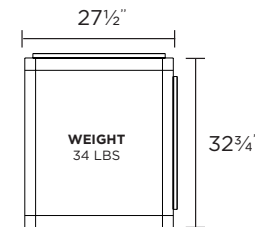
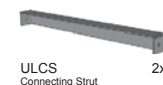
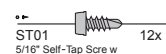
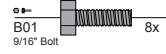

NOTE:

Oversized (OS) module will accommodate backsplash and or wider countertops.

Can be used to extend the length of a base/grill module or to connect modules and change layout direction.

PILLAR MODULE

SPECIFICATIONS

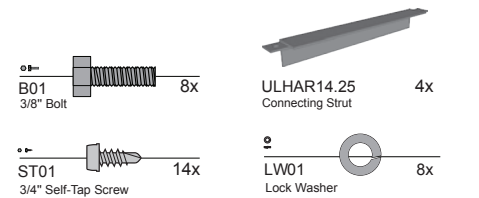
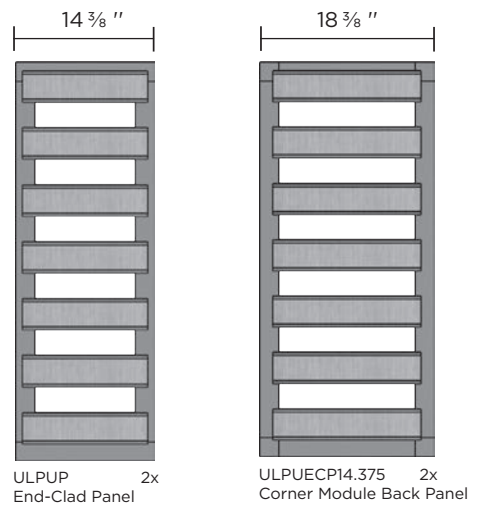
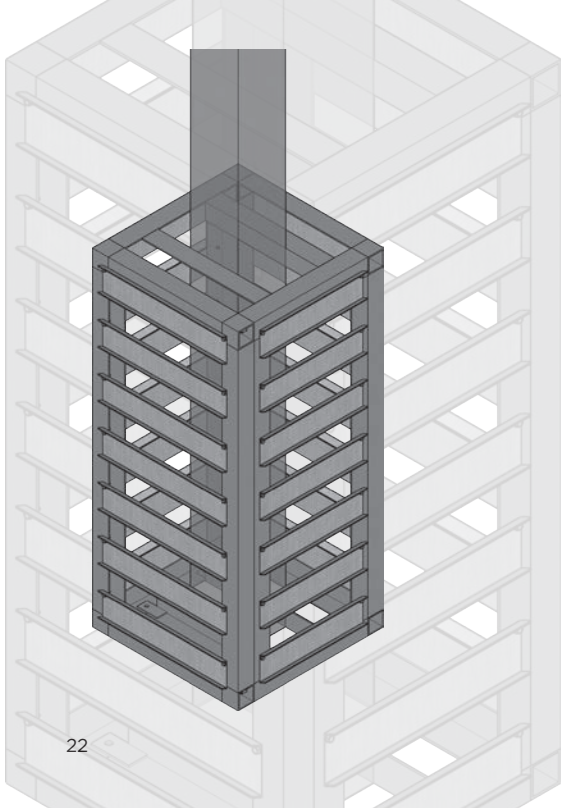

MODEL: UL-PU

NOTE:
28" x 28" pillar cap required if not wrapping post.

MODULE DIMENSIONS
18 1/2" x 18 1/2"

FASCIA PANEL MODULE DIMENSIONS
24" x 24"
(OUTSIDE TO OUTSIDE)

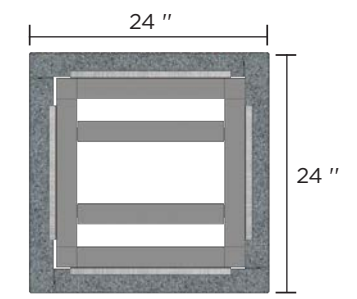
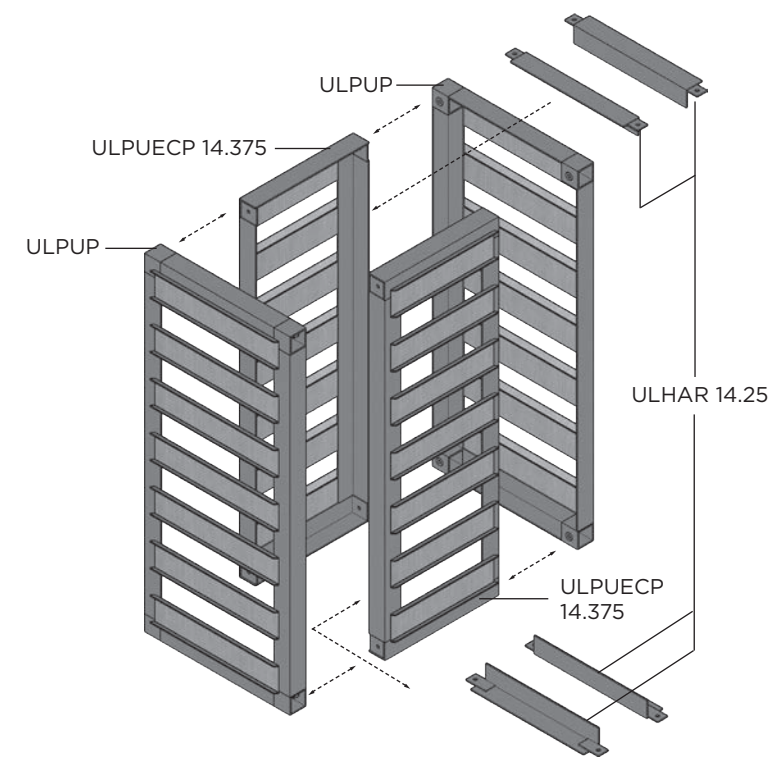

TOP VIEW WITH FASCIA PANELS

PILLAR MODULE

ASSEMBLY

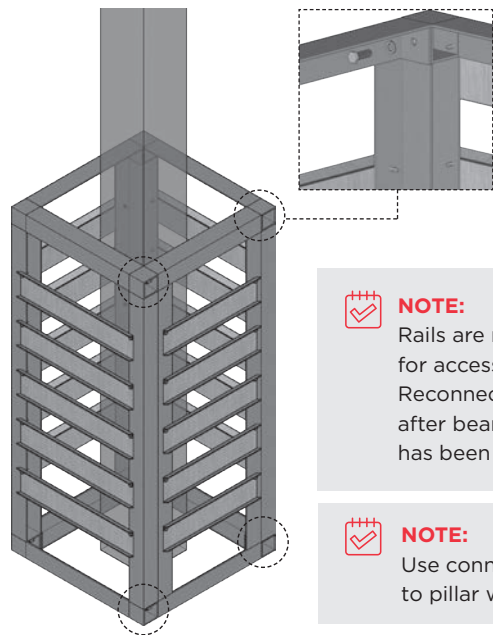

NOTE:

Rails are removed to allow for access for post connection. Reconnect removed rails after beam connection has been made.



NOTE:

Use connecting struts to secure to pillar with interior beam.

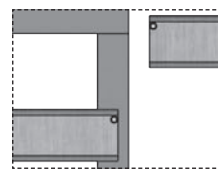
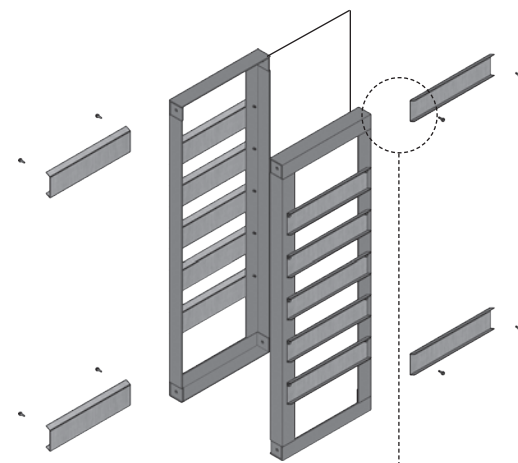
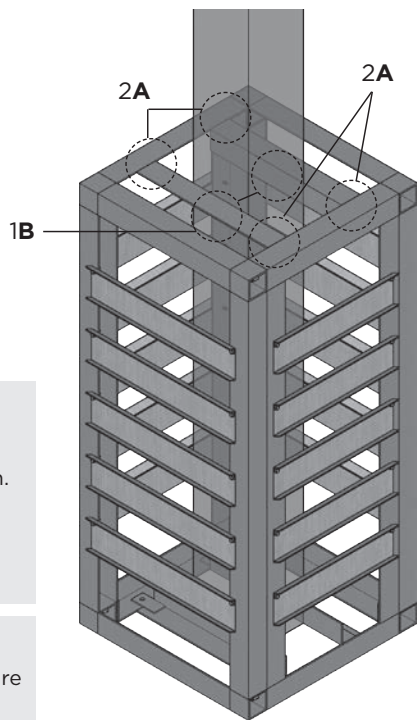

REMOVE INDICATED PARTS AND LABEL FOR LATER INSTALLATION IN SAME LOCATION

FIGURE 1B

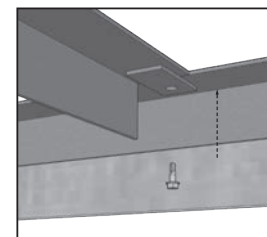
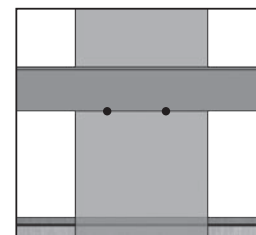

FIGURE 2A



NOTE:

Only the large unit of the corner panel set is used to wrap the pillar module. Use the leftover half units for standard wall work.



NOTE:

Rails are removed to allow for access for post connection. Reconnect removed rails after beam connection has been made.

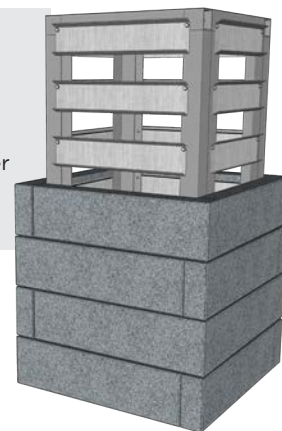

MODEL: UL-PU

BACK CORNER

SPECIFICATIONS/ASSEMBLY

(Used to convert both Corner Module and Oversized Corner Module to a three-sided unit)

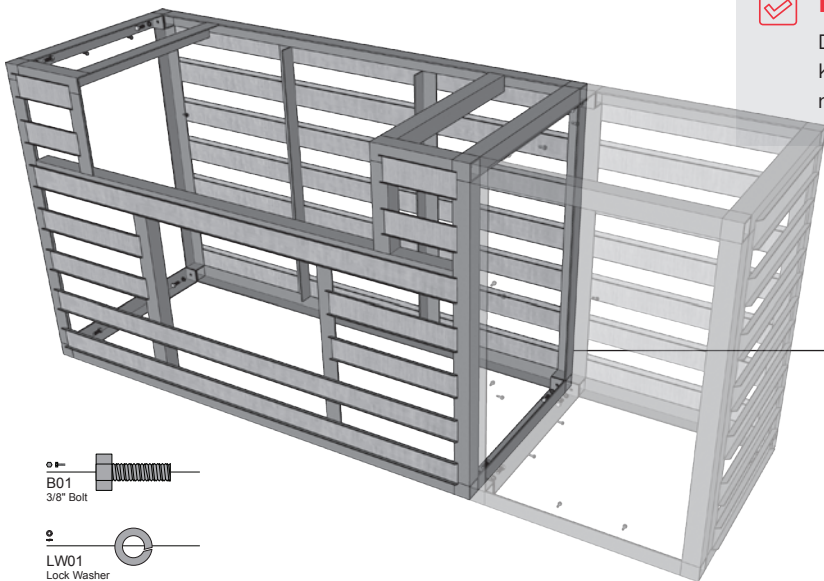

B01
3/8" Bolt

LW01
Lock Washer



NOTE:

Do Not substitute End-Clad Kit as the connections will not match up to Corner Module.

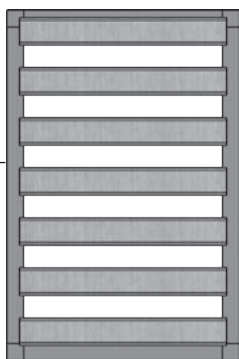

ULCCBP 1X
CORNER MODULE BACK PANEL

MODEL: UL-CC-BP

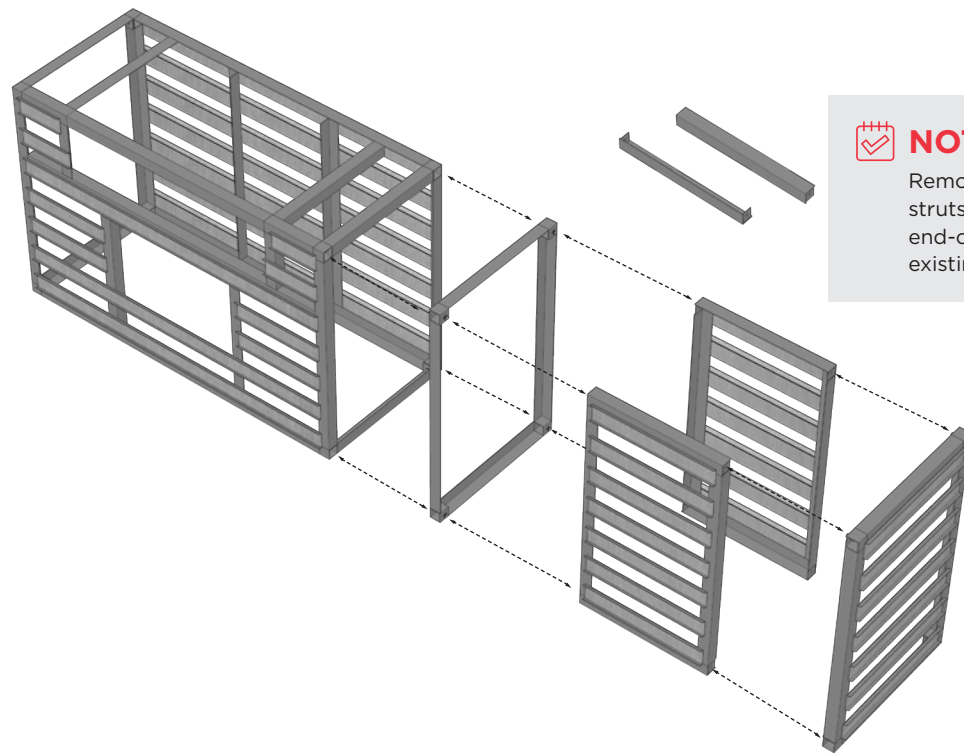

NOTE:

Remove connecting struts and replace with end-clad panel using existing hardware.

END-CLAD KIT

SPECIFICATIONS

(Used to convert base & grill module into stand-alone units)

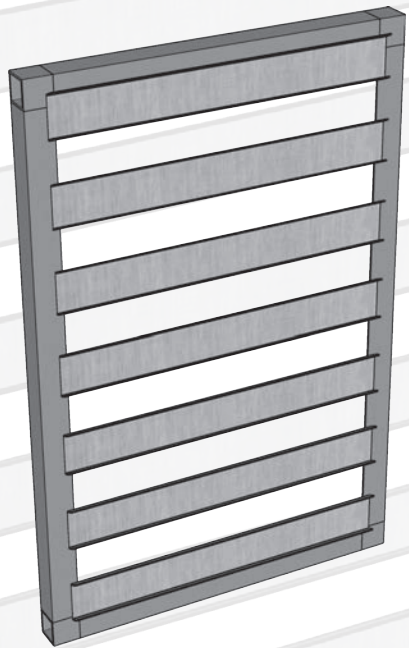

STANDARD

23 1/2 "

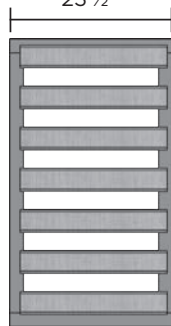

WEIGHT: 11 LBS

OVERSIZED

32 3/4 "

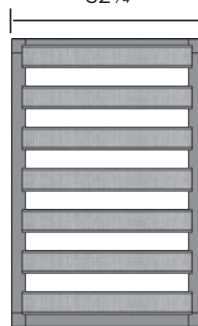

WEIGHT: 16 LBS

MODEL: UL-ECK

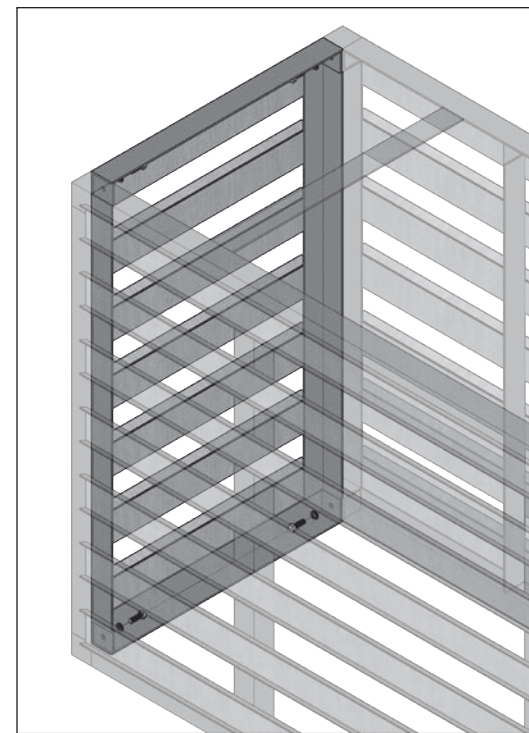

BACKSPLASH

SPECIFICATIONS

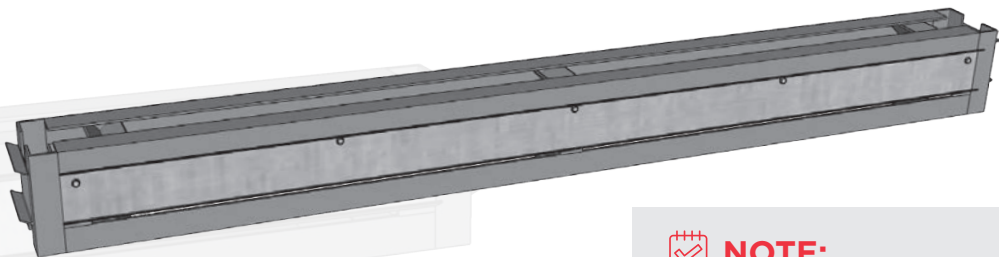

NOTE:

Backsplash Width = 10 $\frac{1}{4}$ " including thickness of front and back fascia panels.

WHAT'S INCLUDED

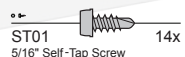
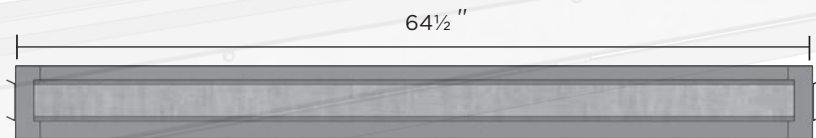

WEIGHT: 15 LBS



NOTES:

1. An additional end-cap rail has been provided so that you can finish the end of the backsplash unit (if you are not extending or connecting to another unit).

2. Multiple units can be connected to each other or use included end rail to make a stand alone unit with 4 finished sides.

3. Each backsplash will accommodate 1 module per unit.

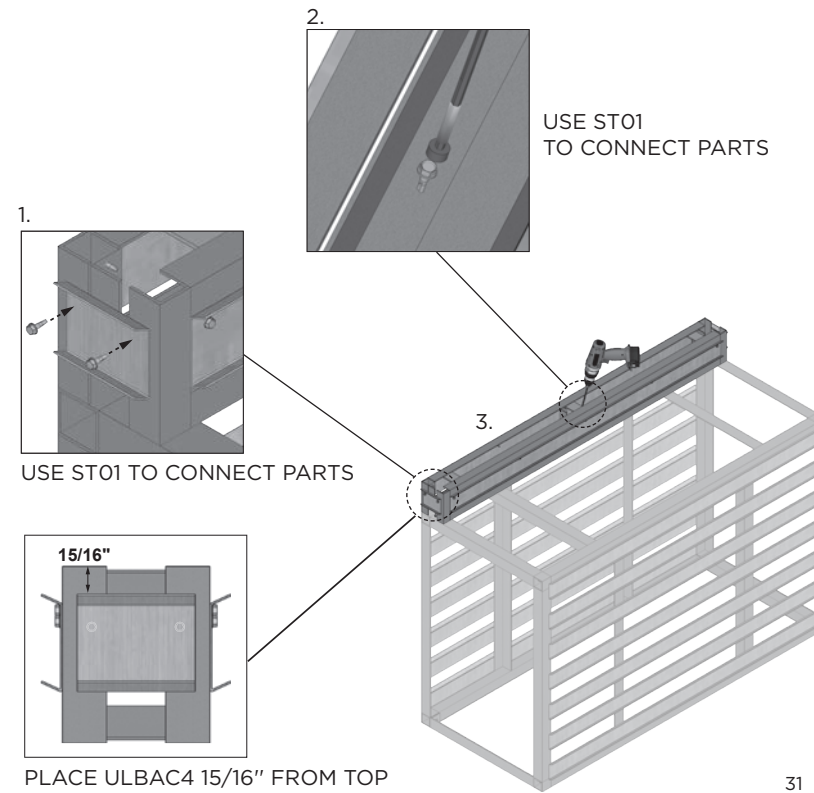

BACKSPLASH CORNER

SPECIFICATIONS

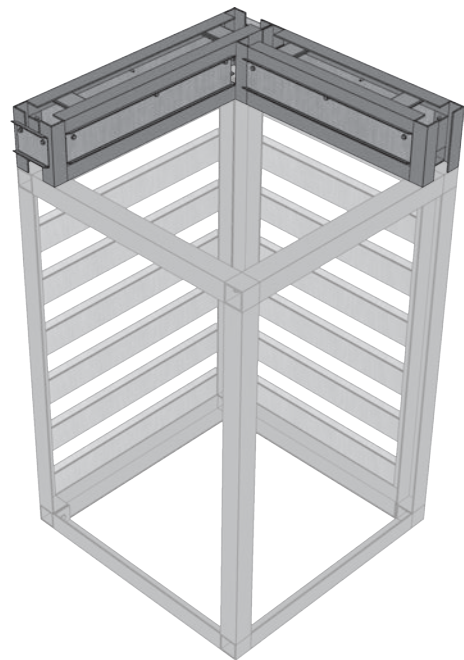

STANDARD WIDTH

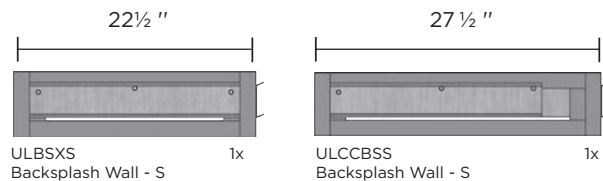

OVERSIZED WIDTH

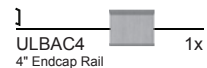
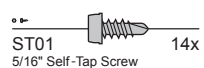
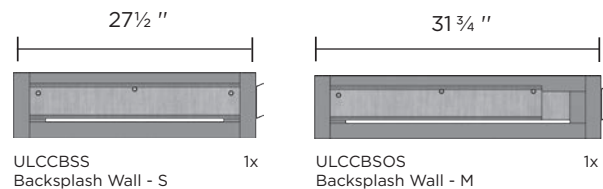

MODEL: UL-BS-CC

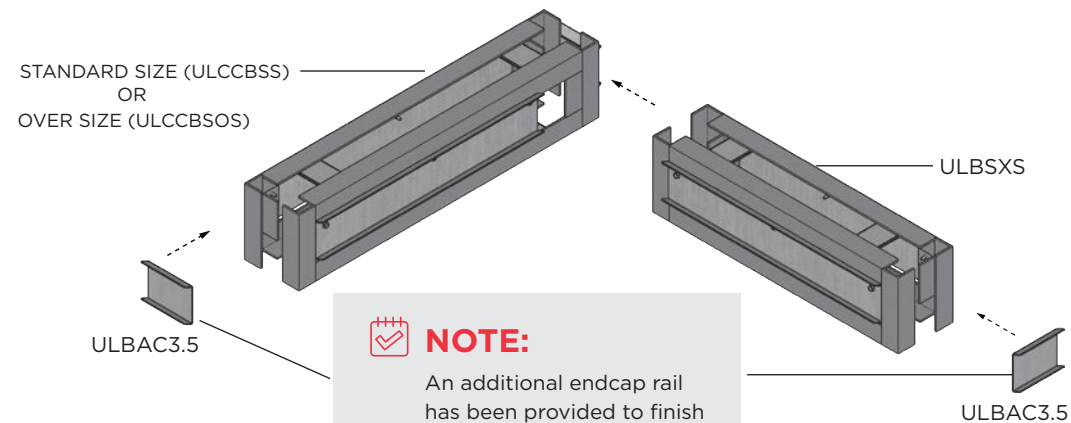

NOTE:

An additional endcap rail has been provided to finish the end of the backsplash unit (if you are not extending or connecting to another unit).

BACKSPLASH

ASSEMBLY

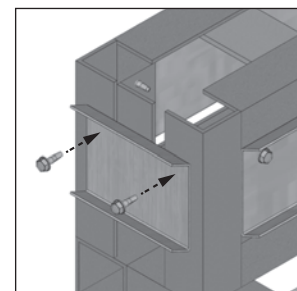
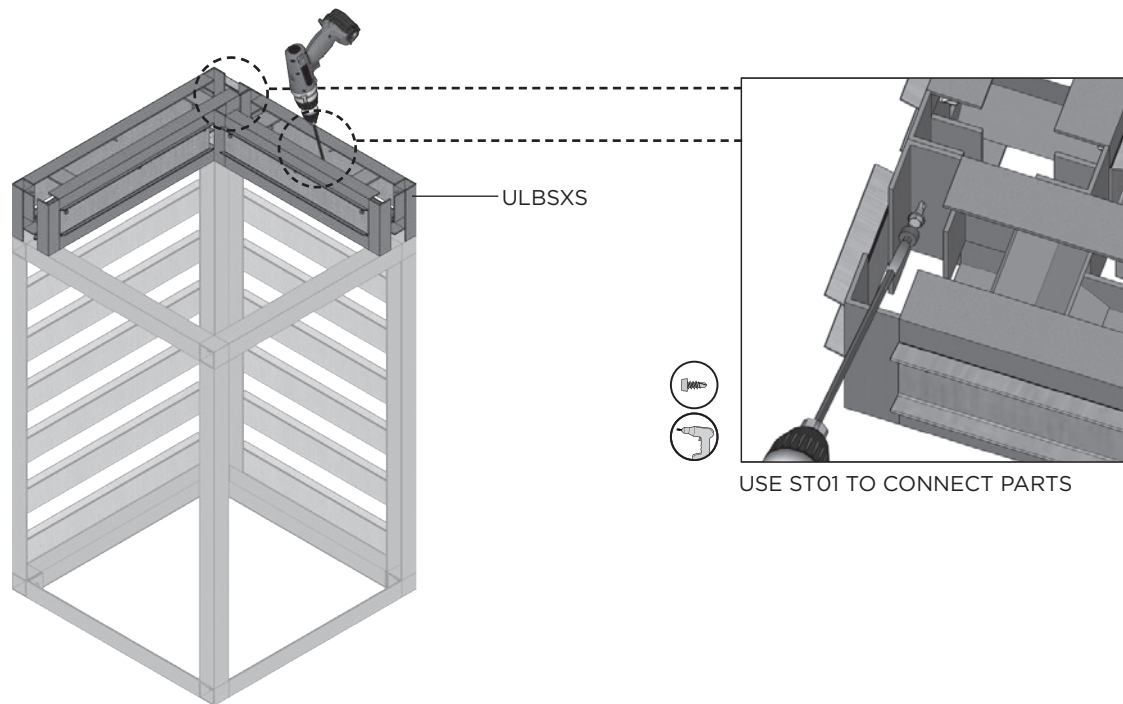

USE ST01 TO CONNECT PARTS

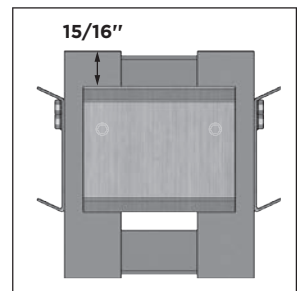

PLACE ULBAC3.5 15/16" FROM TOP

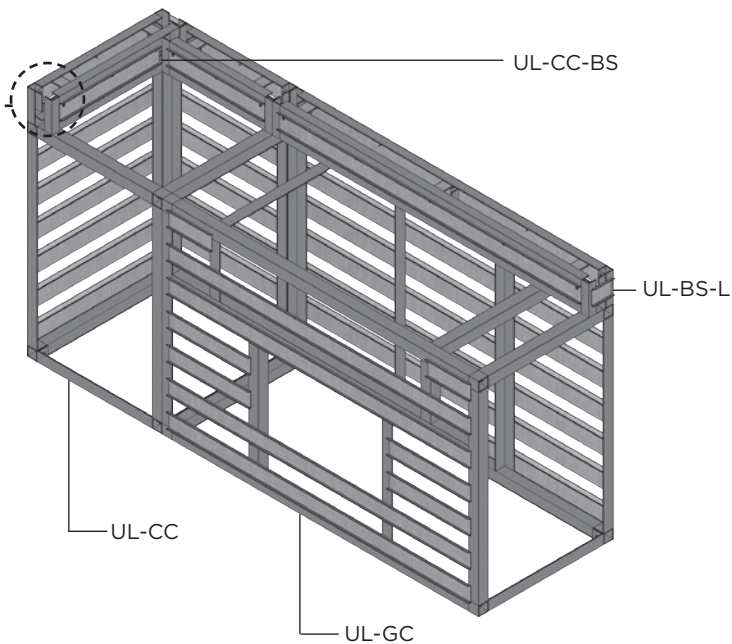

CONNECTING MODULES

STEP BY STEP PROCESS

1. Fully assemble all individual modules prior to connecting.
2. Arrange the modules into the desired layout.
3. Clamp adjoining modules and use included self-tapping screws to connect.

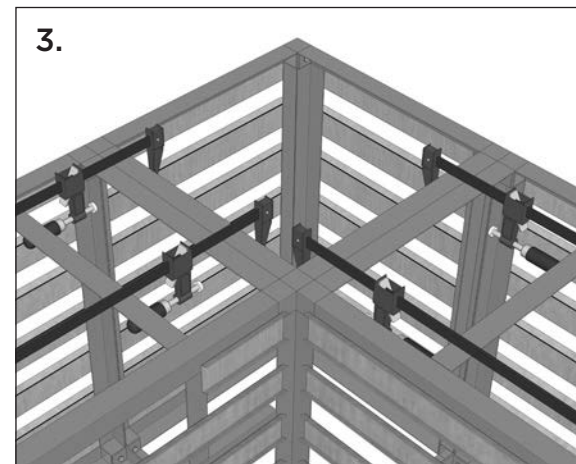
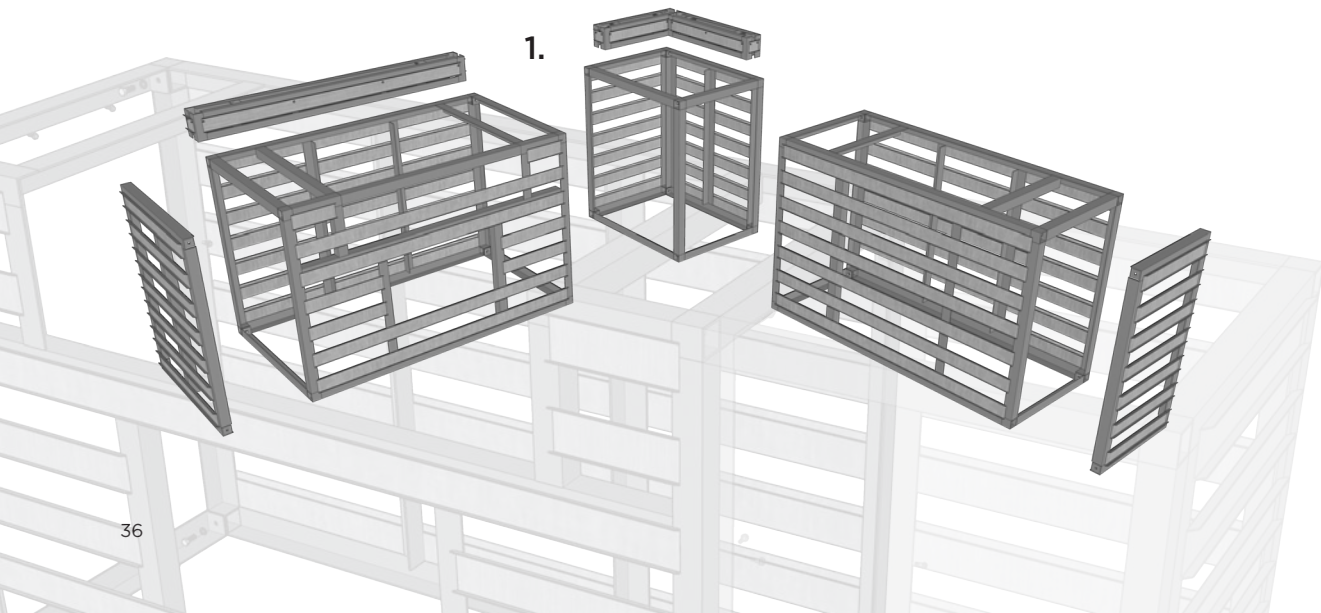

ST01
5/16" Self-Tap Screw 12x



NOTE:

When connecting several modules, additional cross bracing may be required to stabilize the frame.

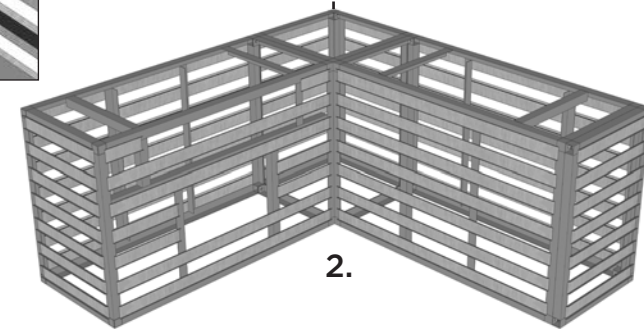

2.

MODULE DIMENSIONS

CALCULATING OVERALL DIMENSIONS

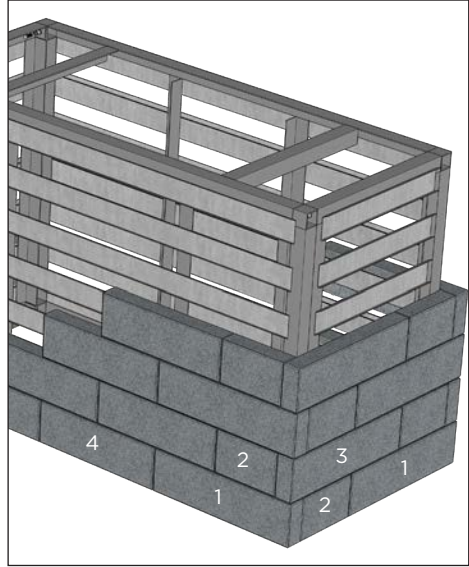

NO-CUT PANEL LAYOUT

Fascia panels are approximately 2½" thick. This width must be added to the aluminum frame dimensions for all visible sides. Example: 64½" (Grill) + 27½" (Corner Module) = 92" Total Length 92" + 5" (2 Panel width) = 97"

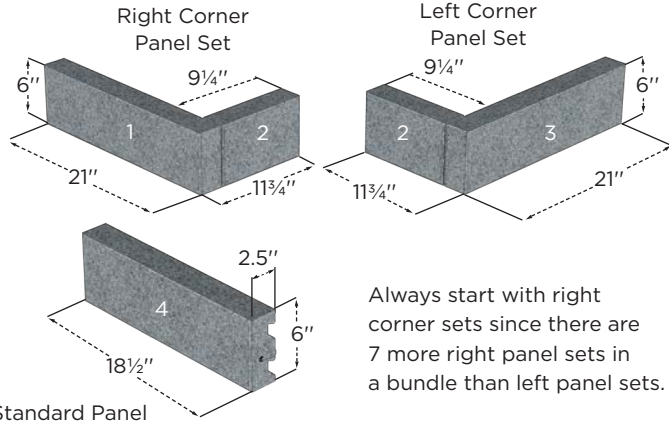

Always start with right corner sets since there are 7 more right panel sets in a bundle than left panel sets.

MODEL: UL-GC /UL-CC

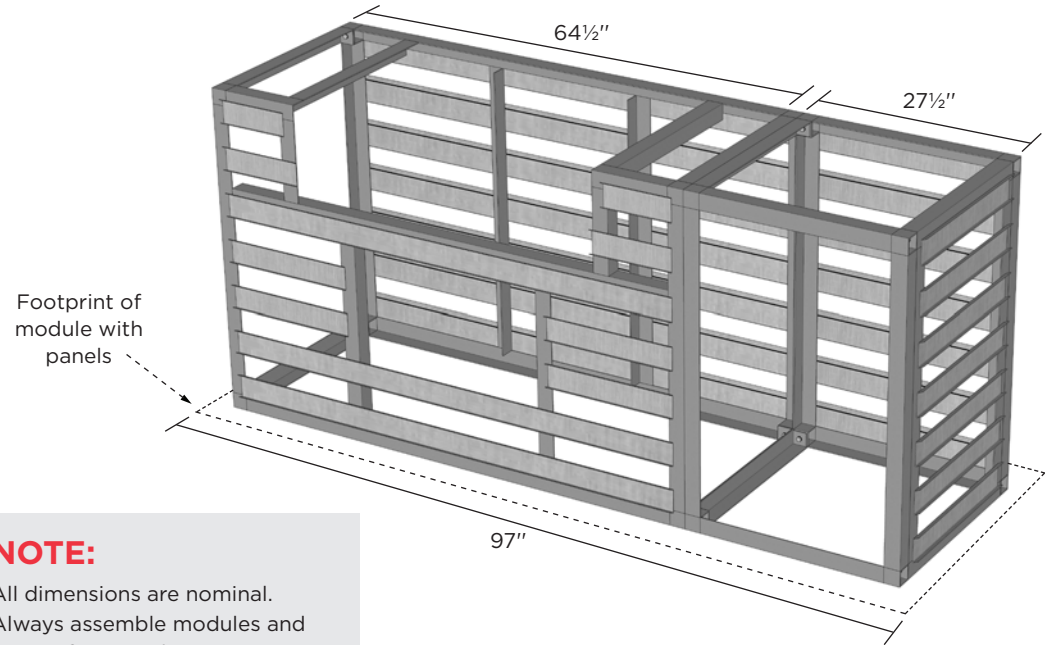

NOTE:

All dimensions are nominal. Always assemble modules and hang a few panels prior to finalizing footprint measurements.

STANDALONE BAR/FIRE TABLE

MODEL: UL-BC + UL-ECK

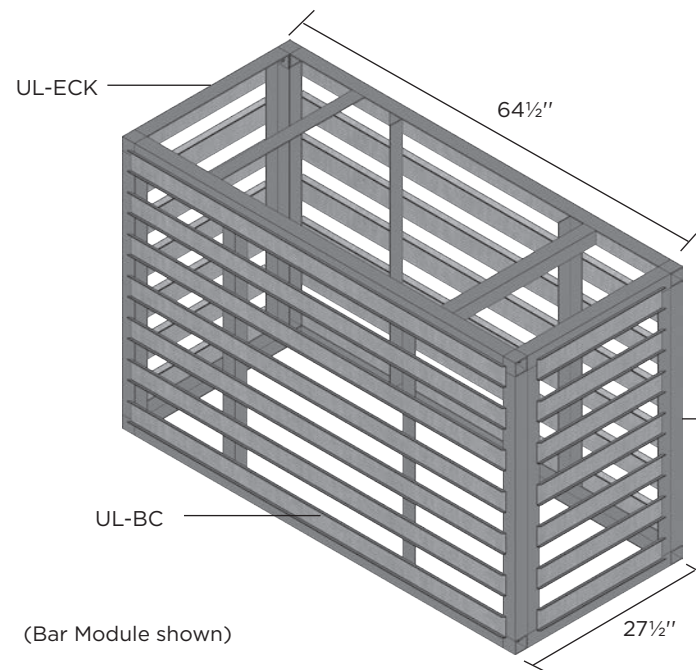

U-CARA® MODULAR SYSTEM

- (1) Base Module-UL-BC
- (2) End Clad Kit-UL-ECK

U-CARA FASCIA PANELS

- Standard Panels - 28
- Corner Sets - 28

Quantities are estimated and may vary depending on modifications made to accommodate cut-outs/appliances. Contractor should field verify for accuracy.

MODEL: UL-GC + UL-ECK

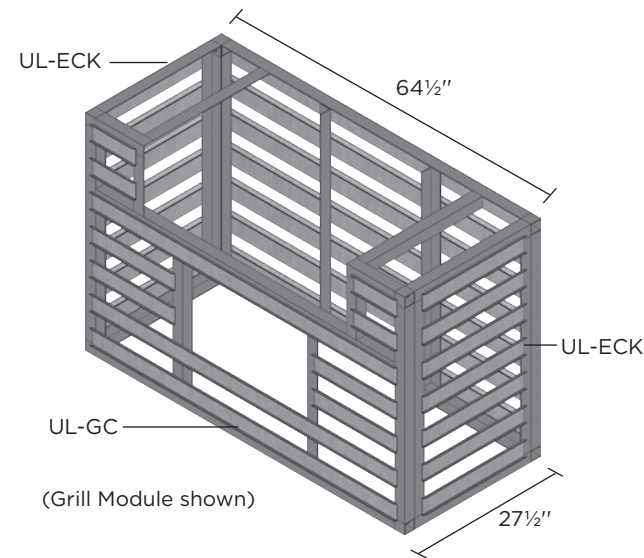

U-CARA® MODULAR SYSTEM

- (1) Grill Module UL-GC
- (2) End Clad Kit UL-ECK

U-CARA FASCIA PANELS

- Standard Panels - 28
- Corner Sets - 28

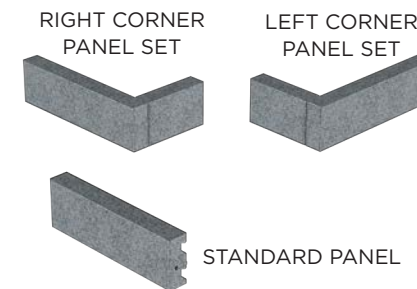

EXTENDING MODULES

GRILL EXTENSION

MODEL: UL-GC / UL-CC / UL-ECK / UL-CC-BP



NOTE:

Base Module can be substituted in place of Grill Module to extend Bar/Fire Table unit.

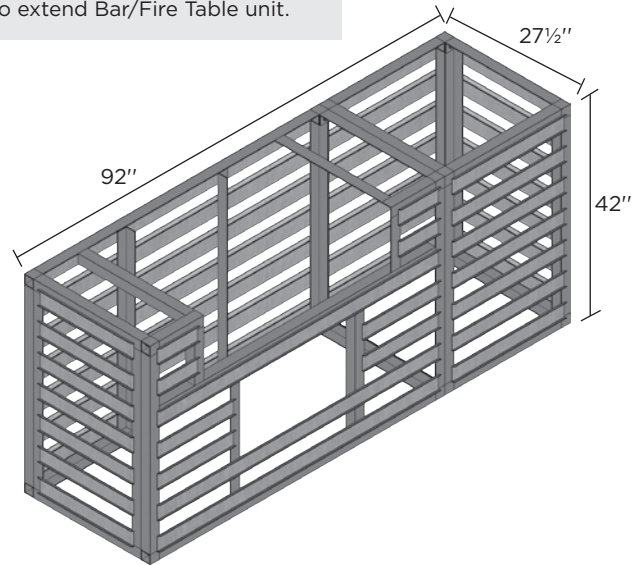

U-CARA MODULAR SYSTEM

- (1) Grill Module UL-GC
- (1) Corner Module UL-CC
- (1) End Clad Kit UL-ECK
- (1) Back End Panel UL-BP

U-CARA FASCIA PANELS

- Standard Panels - 49
- Corner Sets - 28

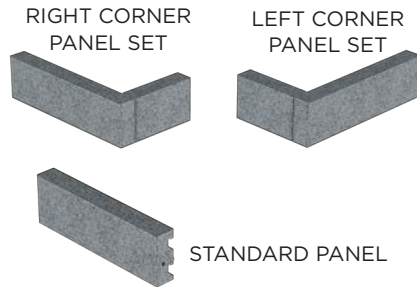

GRILL/BAR COMBO

MODEL: UL-GC / UL-BC / UL-ECK

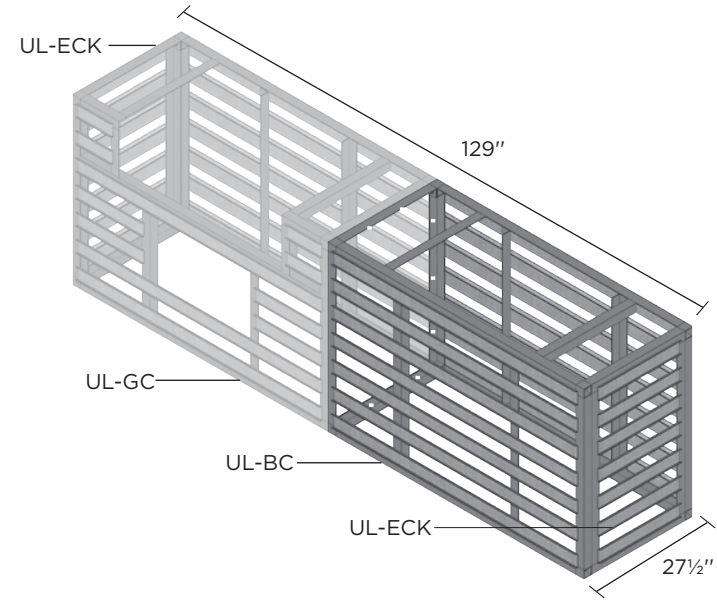

U-CARA MODULAR SYSTEM

- (1) Grill Module UL-GC
- (1) Base Module UL-BC
- (2) End Clad Kit UL-ECK

U-CARA FASCIA PANELS

- Standard Panels - 56
- Corner Sets - 28

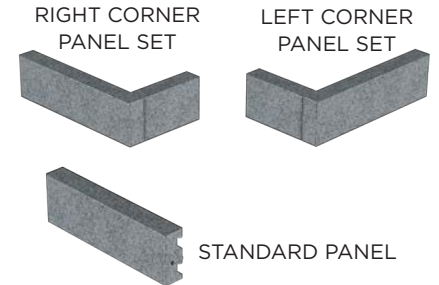

L-SHAPE KITCHEN

U-CARA® MODULAR SYSTEM

- (1) Base Module UL-BC
- (1) Grill Module UL-GC
- (1) Corner Module UL-CC
- (2) End Clad Kit UL-ECK

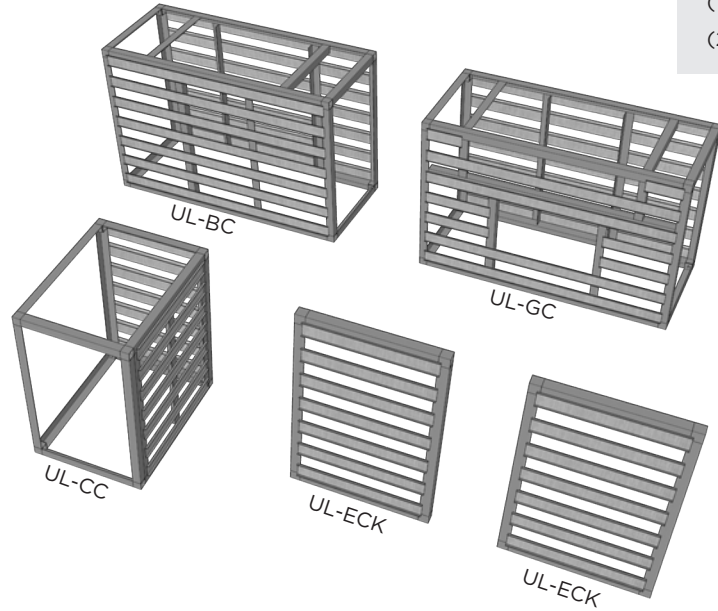

MODEL: UL-BC + UL-GC + UL-CC + UL-ECK

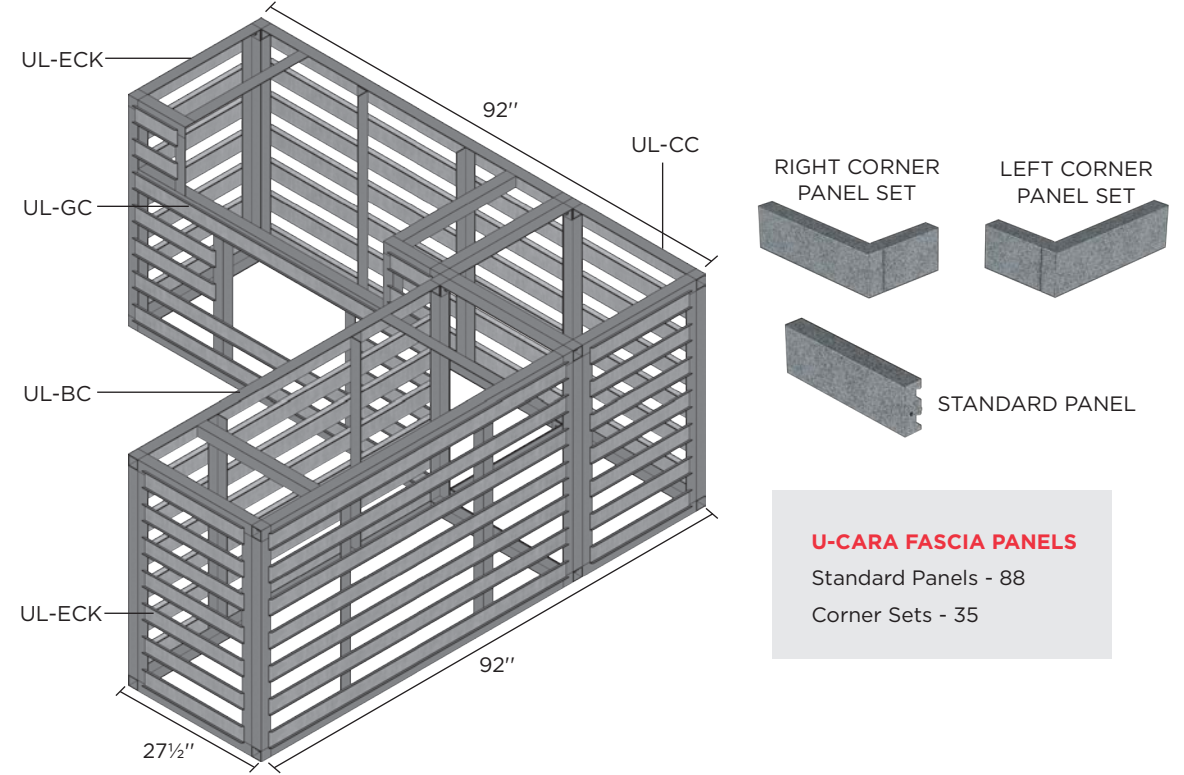

U-SHAPE KITCHEN

U-CARA® MODULAR SYSTEM

- (2) Base Module UL-BC
- (1) Grill Module UL-GC
- (2) Corner Module UL-CC
- (2) End Clad Kit UL-ECK

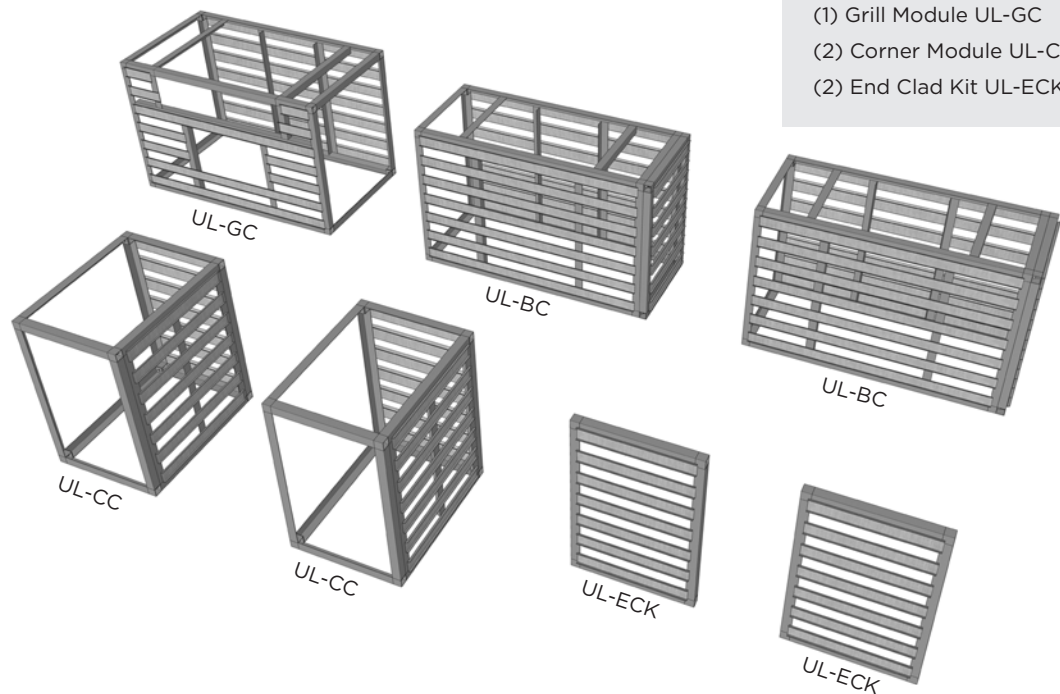

MODEL: UL-BC + UL-GC + UL-CC + UL-ECK

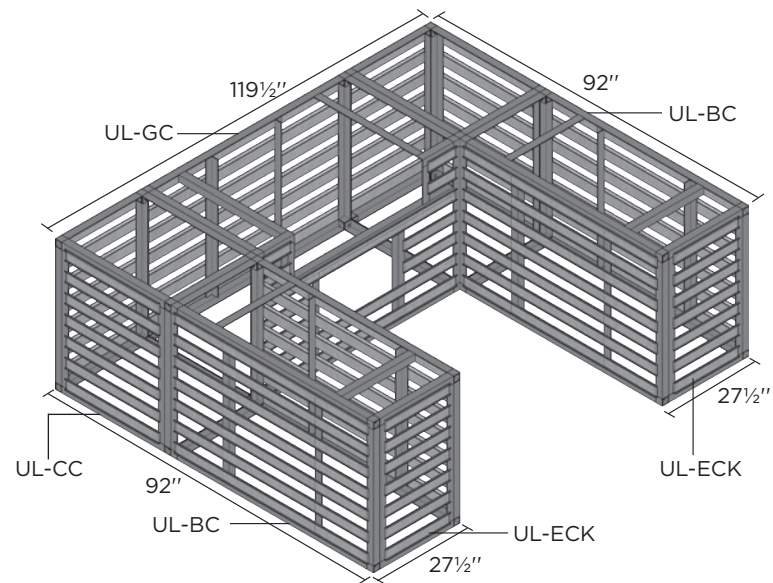

U-CARA FASCIA PANELS

- Standard Panels - 147
- Corner Sets - 42

RIGHT CORNER
PANEL SET

LEFT CORNER
PANEL SET

STANDARD PANEL

U-CARA® MODULAR SYSTEM

THE NEW PARADIGM IN VERTICAL HARDSCAPES



reddot award 2019
winner

The Red Dot Award is an international design award event that appraises the best products created each year. Awards are only given to those products which exhibit the highest level of design and engineering ingenuity.

1 800-UNILOCK | UNILOCK.COM

©2020 HENGSTONE HOLDINGS, INC.
THE U-CARA SYSTEM IS PROTECTED UNDER
US PAT. 9,453,341 (INTERNATIONAL PATENTS PENDING)
U-CARA MODULAR SYSTEMS-PATENT PENDING-GRILLNETICS, FORT COLLINS, CO.

UNILOCK®